

LOC	DIST	P	F	ZONE	LTR	DESCRIPTION	DATE	APPD
AF	50				L	REV PER 0710-0390-95	9/6/95	JR/JG

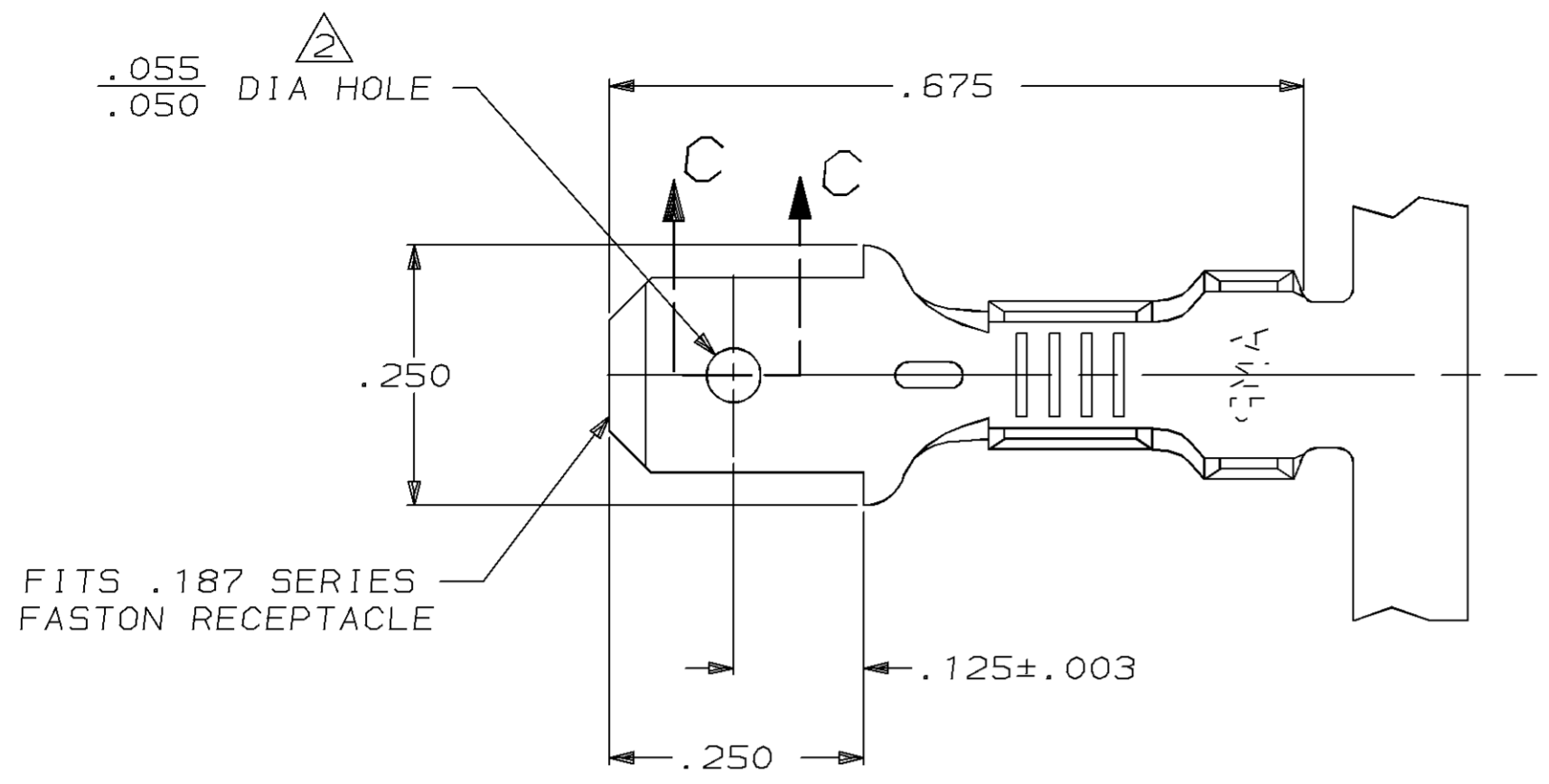

- 1 CONTINUOUS STRIP ON REEL
- 2 NO BURRS PERMISSIBLE AT HOLE. .005 MAX RADIUS PERMISSIBLE ON TOP.

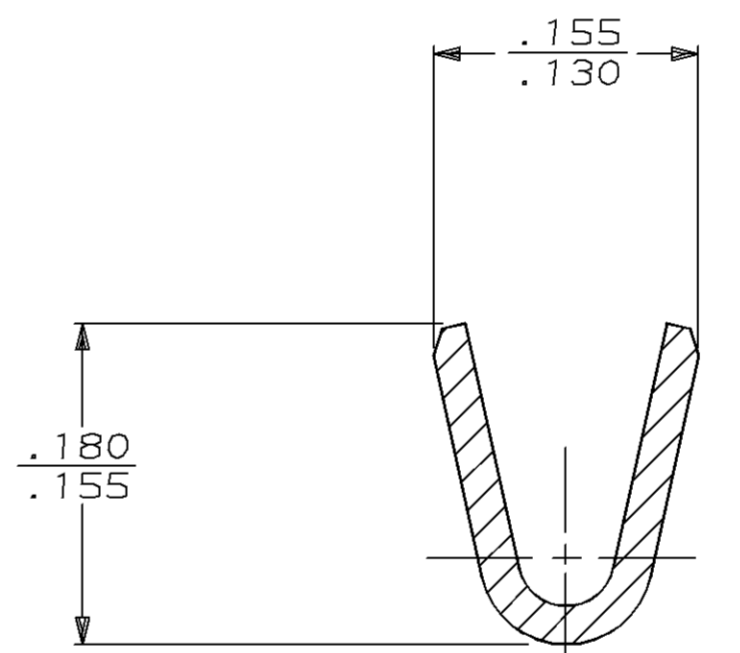
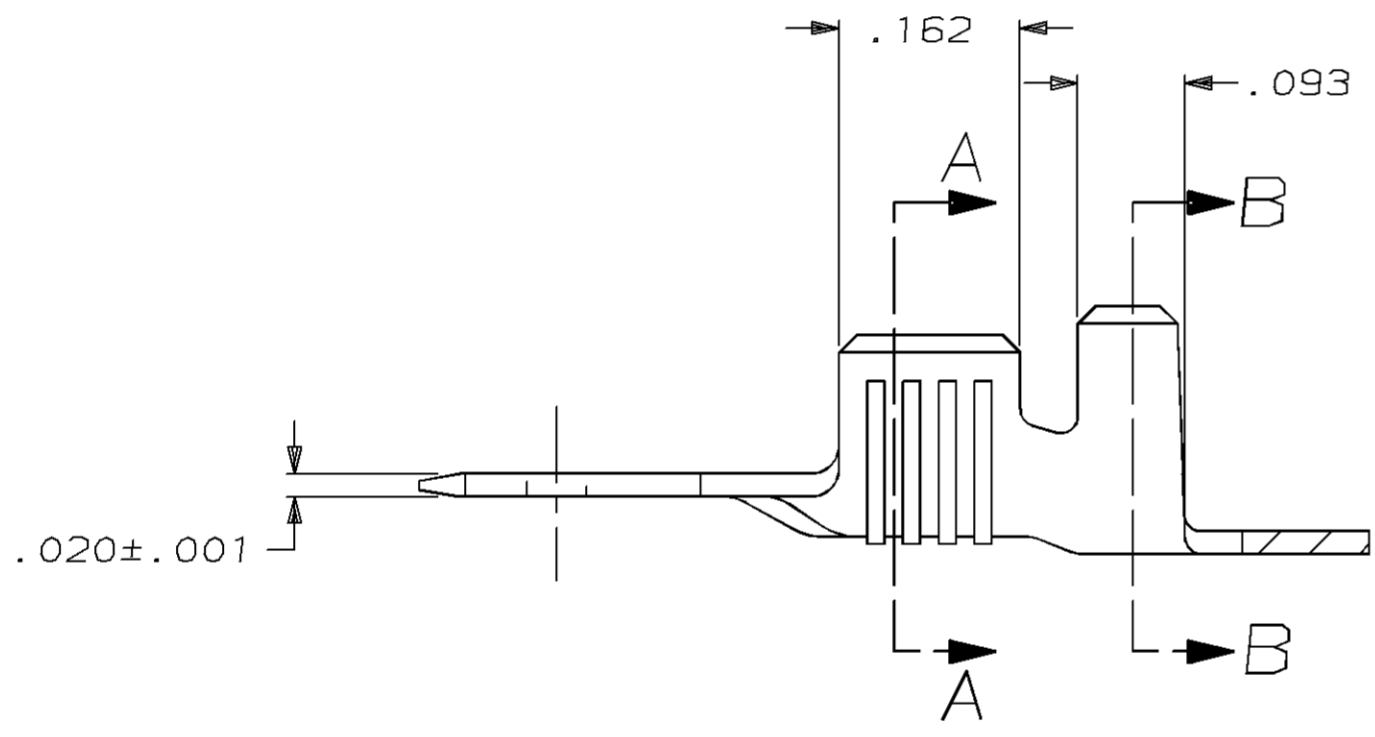

SECTION A-A
SCALE 10:1

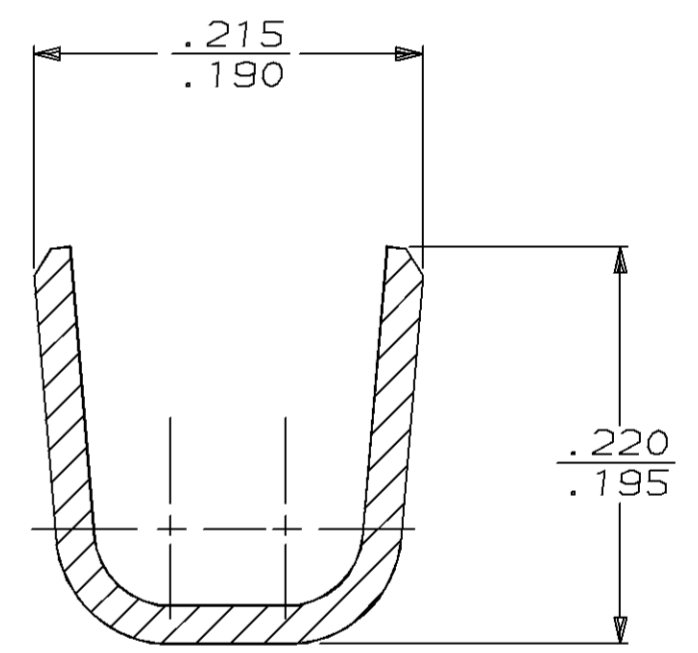

SECTION B-B
SCALE 10:1

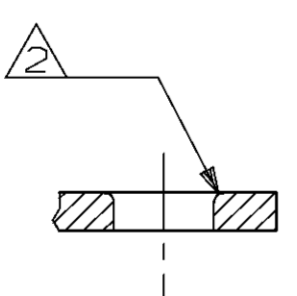

SECTION C-C
SCALE 10:1

0	.180	.218	F	.110	.085	14
					.076	16
					.071	18
TYPE	WIDTH	STRIP LENGTH ±.015	TYPE	WIDTH	±.002 HEIGHT	WIRE
INSUL BARREL CRIMP			WIRE BARREL CRIMP			

TIN .000080 MIN	.120-.150	18-14	60850-2
	.120-.150	18-14	60850-1
FINISH	INSULATION RANGE	WIRE RANGE	PART NO
DR 2/16/89 JR RUTH	AMP INCORPORATED Harrisburg, Pa. 17105		
CHK 2/16/89 MS FEHER			
APPD 2/17/89 C MEYERS			
MATERIAL	NAME		
#2 HARD BRASS	TAB, FASTON TM , .187 SERIES		
FINISH	APPLICATION SPEC	SIZE	FSCM NO
SEE TABLE	-	C	00779
	WEIGHT	SCALE	DRAWING NO
	-	6:1	60850
			SHEET 1 OF 1